

Steam System Accessories

Applications

Steam is often pressurized and superheated for efficient distribution. To maximize heat transfer properties, the steam temperature must then be reduced to saturation level. Kadant desuperheaters are designed to reduce the temperature of superheated steam for optimal heat transfer and efficiency.

Features

- ▶ Desuperheaters sizes range from 2" to 30"
- ▶ No moving parts or special supports required
- ▶ Optional control package available

Benefits

- ▶ Steam system knowledge is applied to design and sizing
- ▶ Consistent process performance
- ▶ Improved heat transfer

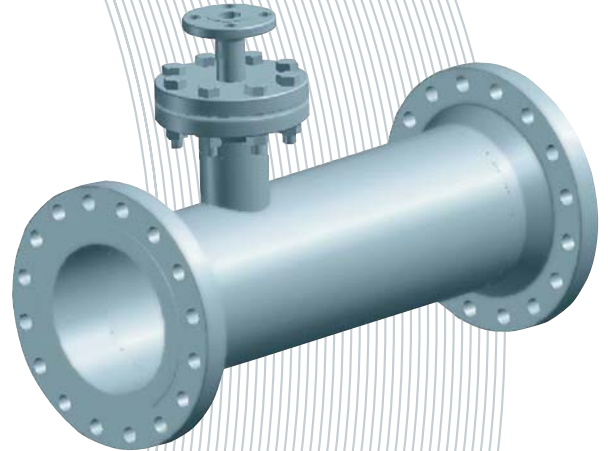

Spray Type

The simple spray type desuperheater is used in applications where the steam load remains relatively constant. Cooling water is injected into the superheated steam through a nozzle. The steam temperature is reduced by evaporative cooling. The maximum turndown ratio of the spray type desuperheater is 2:1.



Spray Type

Ejector Type

The ejector type desuperheater can be used over a wide range of steam flow rates and can operate with a turndown ratio of 50:1. This design uses a small amount of high-pressure steam to atomize the cooling water in the mixing chamber. The expansion of the atomizing steam creates a depression in the mixing chamber while cooling water is ejected into the chamber. Both flows are thoroughly mixed and discharged into the main process steam.

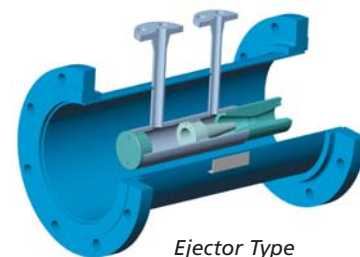

Ejector Type

Venturi Type

The venturi design uses the velocity of the steam to atomize the cooling water and effectively increase the turndown ratio to 10:1. The cooling water entering the unit is preheated in a circulatory chamber located at the entrance of the inner venturi. The water is then introduced into the inner venturi through a series of engineered jet ports and is atomized by the steam.

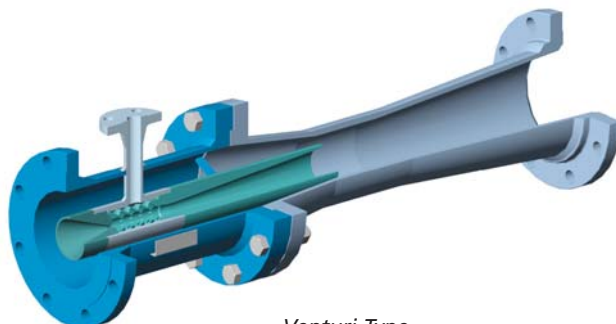

Venturi Type

Kadant desuperheaters are custom designed for each application and are available in various materials. The simple yet efficient designs allow for direct installation into the steam pipeline with flanged connections. All desuperheaters can be installed in either horizontal, vertical, or diagonal pipelines providing there is sufficient straight run both upstream and downstream of the desuperheater.

DESUPERHEATERS

Spray Type

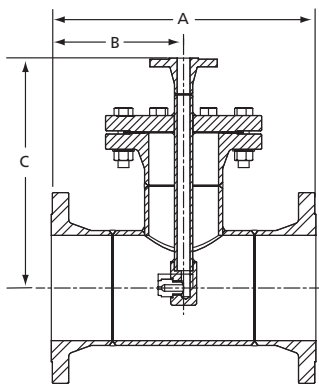

Size (inches)	A	B	C
2	10.00	5.00	9.00
2.5	11.50	5.75	9.75
3	12.25	6.13	10.13
4	14.25	7.13	11.13
5	15.25	7.63	12.75
6	15.25	7.63	13.25
8	16.25	8.13	14.25
10	16.25	8.13	16.50
12	17.25	8.63	16.50
14	18.25	9.13	18.00
16	18.25	9.13	19.00
18	19.25	9.63	20.00
20	20.00	10.00	21.00
24	24.00	12.00	25.00

Venturi Type

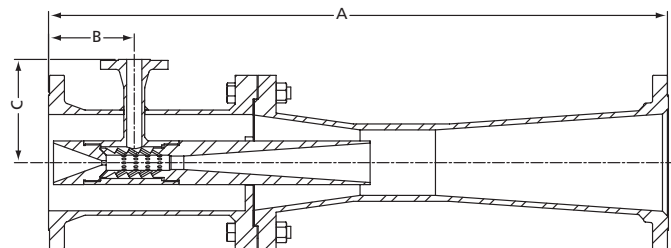

Size (inches)	A	B	C
2	13.00	2.85	4.50
2.5	16.00	3.38	4.88
3	18.70	3.88	5.25
4	25.50	5.00	5.25
5	32.00	5.00	6.00
6	37.30	5.00	7.00
8	48.90	6.20	8.00
10	60.30	7.00	9.00
12	74.30	9.70	11.00
14	81.80	11.12	12.00
16	93.50	12.30	14.00

Ejector Type

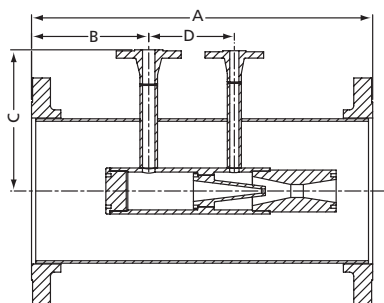

Size (inches)	A	B	C	D
3	15.00	5.00	5.00	4.50
4	16.37	5.75	5.37	4.87
5	16.50	5.75	6.37	5.00
6	16.50	5.75	6.75	5.00
8	20.37	6.50	8.37	6.37
10	21.00	6.50	10.00	6.37
12	22.00	6.50	12.00	7.37
14	26.00	7.00	14.50	8.37
16	26.00	8.00	15.50	9.00
18	28.00	8.00	17.00	9.50
20	30.00	8.00	18.00	10.00
24	34.00	9.50	20.00	12.00

Notes:

1. Kadant desuperheater dimensions can be engineered to fit existing piping and flange requirements.
2. Standard dimensions are subject to change without notice.
3. Standard material of construction is carbon steel (other material available upon request).
4. Optional control package is available.

KADANT
AN ACCENT ON INNOVATION

Kadant is a leading global supplier of products and services that improve productivity and quality in paper production and other process industries. For the nearest location and contact, visit our Website.

www.kadant.com

Contact us:

KADANT JOHNSON INC.
805 Wood Street
Three Rivers, MI 49093 USA

Tel: +1-269-278-1715
Fax: +1-269-279-5980
Email: info@kadant.com

Desuperheater-1001 3/2008
replaces Desuperheater-1000
© 2008 Kadant Inc.